

**THE EFFECT OF FINANCIAL PERFORMANCE RATIOS ON CONVENTIONAL BANK
PROFITABILITY IN INDONESIA STOCK EXCHANGE**

¹Ahmad Azmy, ²Iqbal Febriansyah, ³Anita Munir

^{1,2,3}School of Management & Leadership, Tanri Abeng University

ABSTRACT

This study aims to analyze the effect of the ratio of financial performance to the profitability of private conventional commercial banks listed on the Indonesia Stock Exchange. Retrieval of data using financial statements from fourteen conventional commercial banks. The independent variables used include Capital Adequacy Ratio (CAR), Operational Income Operating Expenses (BOPO), Non Performing Loans (NPL), and Loan to Deposit Ratio (LDR). The profitability variable is proxied by Return on Assets (ROA). This type of research is quantitative that uses secondary data. The analysis was carried out using multiple regression analysis. The results showed that, CAR and NPL had no effect on ROA, while BOPO and LDR had a significant effect on ROA. Then the F Test results show that CAR, NPL, BOPO, and LDR simultaneously influence ROA

Keywords: *Performance Financial, Profitability, Conventional Bank*

ABSTRAK

Penelitian ini bertujuan untuk menganalisis pengaruh rasio kinerja keuangan terhadap profitabilitas bank umum konvensional swasta yang terdaftar di Bursa Efek Indonesia. Pengambilan data menggunakan laporan keuangan dari empat belas bank umum konvensional. Variabel independen yang digunakan meliputi Rasio Kecukupan Modal (CAR), Biaya Operasional Pendapatan Operasional (BOPO), Non Performing Loans (NPL), dan Loan to Deposit Ratio (LDR). Variabel profitabilitas diproksi dengan Return on Asset (ROA). Jenis penelitian ini adalah kuantitatif yang menggunakan data sekunder. Analisis dilakukan dengan menggunakan analisis regresi berganda. Hasil penelitian menunjukkan bahwa, CAR dan NPL tidak berpengaruh pada ROA, sedangkan BOPO dan LDR berpengaruh signifikan terhadap ROA. Kemudian hasil Uji F menunjukkan bahwa CAR, NPL, BOPO, dan LDR secara simultan mempengaruhi ROA.

Kata Kunci: Kinerja Keuangan, Profitabilitas, Bank Konvensional

INTRODUCTION

Banks are intermediaries in the process of transferring funds from parties who have excess funds to those who need funds (Mawaddah, 2015). Kashmir (2002) explains that the banking function consists of Commercial Banks and Rural Credit Banks. These two types of financial institutions regulate the flow of public financial flows where there is an element of profitability in running a financial business. Banks always try to increase their profitability in financial business competition. Dendawijaya (2000) explains that the financial performance of banking companies can be measured one of them through Return on Assets (ROA). This ratio illustrates the level of bank's ability to manage assets held for profit. The conventional banking performance data with the Return on Assets (ROA) indicator are as follows:

Table 1. ROA Conventional Bank

Year	<i>Return On Asset (ROA)</i>
2013	3,08%
2014	2,85%
2015	2,32%
2016	2,23%
2017	2,45%

Sources: Statistik Perbankan Indonesia, 2017

The table above explains that the Return on Assets (ROA) that occurred decreased causing the profitability of banking assets to decline. The data explains that in 2013 Return on Assets was 3.08% and decreased by 2.23%. However, in 2017 Return on Assets increased by 2.45%. The data above shows that there are several reasons why bank profitability can change depending on the economic situation. Rizkika, Khairunnisa, & Dillak (2017) explained that the profitability of commercial banks is influenced by the ability of the safe level of lending and the balance between operating expenses & income. Haritsman & Usman (2017) and Sutrisno (2018) revealed that maintaining bank profitability is how to maintain capital adequacy ratios and safe levels in lending. Therefore, it is interesting to analyze what factors affect the profitability of commercial banks with the condition of declining banking performance. Manurung (2015) explains that the ratio of Operating Costs and Operating Income (BOPO), Capital Adequacy Ratio (CAR), Net Interest Margin (NIM), and Non-Performing Loans (NPL) have a significant effect on Return on Assets (ROA). Putrianingsih and

Yulianto (2016) stated that Non-Performing Loans (NPL) had a significant negative effect on Return on Assets (ROA).

Hutagalung et al (2013) explained that the ratio of Non-Performing Loans (NPL), Operational Costs and Operating Income (BOPO) and Net Interest Margin (NIM) had a significant effect on Return on Assets (ROA). The ratio also has a significant effect on Return on Assets (ROA). Harun (2016) explains that banking profitability is influenced by the ability to maintain operational balance to maintain the soundness of financial business. Comparison with several 2013, which was originally 3.08% decreased to 2.45% in 2017, as discussed in the previous description. This study is interesting to analyze the causes of ups and downs in bank profitability which are limited by capital adequacy ratios (CAR), operational balance ratios (BOPO), lending ratios (LDR), and credit security level ratios (NPLs). The position of this study will analyze how the ability of banks to maintain profitability. Look at previous research and changes in financial ratios that are so fast. Then this study will analyze whether the results are different and be able to provide a

previous studies that a lot of financial indicators are used to measure the ability of banks in order to achieve business targets.

The condition of the financial ratios of banking companies that are often changing, allows the results of research that has been done before will experience differences with facts or reality in the future. Therefore, to test the consistency of the results of previous studies, it is necessary to do research again. Although in the table above the level of Return on Assets (ROA) of Conventional Commercial Banks has tended to decline in recent years. As of comprehensive picture of banking performance.

THEORETICAL REVIEW

Capital Adequacy Ratio (CAR)

Pinasti and Mustikawati (2018) explained that Capital Adequacy Ratio (CAR) is a financial ratio related to bank capital where the amount of capital of a bank will affect whether or not a bank can efficiently run its activities. Sudarmawanti and Pramono (2017) revealed that increasing circulation and decreasing Capital Adequacy Ratio (CAR) will show a decrease in bank assets that

can still be covered by available bank equity, the higher the CAR, the better the bank's condition. The greater the Capital Adequacy Ratio (CAR), the greater the bank's profits. Bernardin (2016) explains that Capital Adequacy Ratio (CAR) has an influence on Return on Assets (ROA). Kasmir (2002) explains that the method of calculating the Capital Adequacy Ratio (CAR) can be done with the following formulation:

Capital Adequacy Ratio = Capital/ATMR x 100

Non Performing Loan (NPL).

Putrianingsih and Yulianto (2016) explained that credit risk is a risk that occurs because loan repayments or loan principal cannot be made within the due date. Haneff et al (2012) explained that the Non-Performing Loan (NPL) is an indicator to measure how the ability of banks to maintain the level of lending to consumers. Yogianta (2013) explains that NPL shows the ratio of problem loans to the total loans granted. Banks are not only required to provide credit but banks must also conduct a review process in providing credit.

Non-Performing Loan (NPL), is a ratio that describes the level of problem loans experienced by banks or often known as bad loans. Hindarto (2011)

explains that Non-Performing Loans (NPL) have a significant effect on Return on Assets (ROA). This ratio is a form of credit risk held by banks. So, the higher the Non-Performing Loan (NPL), the higher the non-performing loans experienced by banks. Bank Indonesia Regulation 2013 has set a maximum non-performing loan (NPL) limit of 5%. Siamat (2004) explains that credit risk is the risk caused by the failure or inability of customers to repay loans received from banks, including interest, as specified period. The formulation for calculating Non-Performing Loans (NPL), is as follows:

NPL = Problem Loans / Total Loans x 100
Operating Costs and Operating Income (BOPO)

Operating Costs and Operating Income (BOPO), is the ratio of operating costs to bank operating income. Hakim & Sugianto (2018) and Ningsukma & Rafsanjani (2016) explained that the BOPO ratio has an influence on Return on Assets (ROA). Matindas et al (2010) suggested that the lower the ratio of Operating Costs and Operational Revenues (BOPO), the more efficient banks use operational costs in running their business activities. Therefore, the profits obtained by banks will be even

greater, and vice versa if the ratio of Operational Costs and Operating Income (BOPO) is getting higher, the more inefficient banks use operational costs in carrying out operational activities. Bank Indonesia Regulation 2013 stipulates that the maximum limit of Operational Costs and Operating Income (BOPO) ratio is 85%. The formulation for calculating BOPO ratio values is as follows:

BOPO: $\text{Operational Cost} / \text{Operating Income} \times 100$

Loan to Deposit Ratio (LDR)

Dendawijaya (2000) explains the definition of Loan to Deposit Ratio (LDR) is a ratio that measures the level of ability of banks to repay withdrawals of funds made by depositors through loans provided as a source of bank liquidity. If the amount of credit increases higher than the increase in the amount of funds raised, the value of the Loan to Deposit Ratio (LDR) will also be higher. Because of the high Loan to Deposit Ratio (LDR), the level of bank liquidity will be lower. Alifah (2014) shows that the Loan to Deposit Ratio (LDR) has implications for profitability proxied by Return on Assets (ROA). Based on Bank Indonesia regulations in the 2015 Bank Indonesia Regulation the lower limit of Loan to Deposit Ratio (LDR) is 78% and the upper

limit of Loan to Deposit Ratio (LDR) is 92%. The formulation for calculating the Loan to Deposit Ratio (LDR) value is as follows:

LDR = amount of credit given / total third-party funds x 100

Return On Asset (ROA)

Kasmir (2002) explains Return on Assets (ROA) is one of the ratios used to measure the level of bank profitability. Dendawijaya (2000) strengthens the Return on Assets (ROA) indicator is a ratio that illustrates the level of bank's ability to manage assets owned to obtain profits. The higher the Return on Assets (ROA) of a bank, means the higher the profitability obtained by the bank through its assets. The formulation for calculating Return on Assets (ROA) is as follows:

ROA = Earning Before Tax / Total Assets x 100

Relationship Between CAR & ROA

Capital Adequacy Ratio (CAR) is a ratio that shows how much the minimum capital adequacy required by Bank Indonesia is able to be fulfilled by banking companies. The higher the Capital Adequacy Ratio (CAR), the greater the capital owned by a bank by developing its business activities. This indicates that the profits to be obtained

by banks will also increase along with the increase in capital that can be used to develop the bank's business. Some studies state that there is an influence between Capital Adequacy Ratio (CAR) on Return On Assets (ROA) (Hantono, 2017; Vernanda & Widyarti, 2016; and Anggraeni & Suardika, 2014). Therefore Capital Adequacy Ratio (CAR) is assumed to have a significant effect on Return On Assets (ROA).

H1: Capital Adequacy Ratio (CAR) has a significant effect on Return on Assets (ROA).

Relationship NPL & ROA

Non Performing Loans (NPLs) are ratios that describe the level of problem loans that must be accounted for by banks. Therefore, banks are required to reduce the Non Performing Loan (NPL) as low as possible to minimize potential losses. So the lower the Non Performing Loan (NPL), the higher the potential profit to be obtained by the bank. Hakim & Sugianto (2018) concluded that the Non Performing Loan (NPL) had a significant negative effect on Return On Assets (ROA). The same thing was explained by Bhattarai (2016) that Non Performing Loans (NPL) had a significant negative effect on Return On Assets (ROA). Therefore Non Performing Loans

(NPL) are considered as variables that have a significant influence on Return On Assets (ROA).

H2: Non Performing Loans (NPL) have a significant effect on Return on Assets (ROA).

Relationship BOPO & ROA

Operational Cost and Operating Income Ratio (BOPO) is a ratio that shows the level of bank income through operational activities, by suppressing or streamlining operational costs. So that the lower the ratio of Operating Costs and Operating Income (BOPO), the more efficient the bank in its operational activities. This indicates the level of bank profitability which will also increase. Several studies have concluded that the BOPO ratio has an influence on Return on Assets (ROA) (Stephani et al, 2017; and Bilian & Purwanto, 2017). Therefore the ratio of Operating Costs and Operating Income (BOPO), is assumed to have a significant effect on Return On Assets (ROA).

H3: Operating Costs and Operating Income (BOPO) have a significant effect on Return On Assets (ROA).

Relationship LDR & ROA

Loan to Deposit Ratio (LDR) is a ratio that illustrates the level of the bank's ability to offset the amount of

credit extended against the amount of third party funds received by the bank to be returned. So if the Loan to Deposit Ratio (LDR) increases, then the profit received by the bank will also increase from the results of the loans extended, and vice versa. Research conducted by Soares & Yunanto (2018), Muttaqin (2017), and Azmy (2018) concluded that the Loan to Deposit Ratio (LDR) has a significant effect on Return on Assets (ROA). Therefore Loan to Deposit Ratio (LDR) is considered to have a significant effect on Return On Assets (ROA).

H4: Loan to Deposit Ratio (LDR) has a significant effect on Return on Assets (ROA).

Relationship of CAR, NPL, BOPO, LDR, and ROA. In the previous explanation has been discussed about the potential of independent variables (independent) in influencing the dependent variable (dependent). Previous research conducted by Alifah (2014) states that, CAR, NPL, BOPO, and LDR simultaneously influence ROA. Therefore it can be assumed that the entire independent variable simultaneously or jointly has an influence on the dependent variable.

H5: CAR, NPL, BOPO, and LDR simultaneously influence ROA.

The discussion in the study of theory and the formation of hypotheses in the previous descriptions underlie the creation of the following framework of thought:

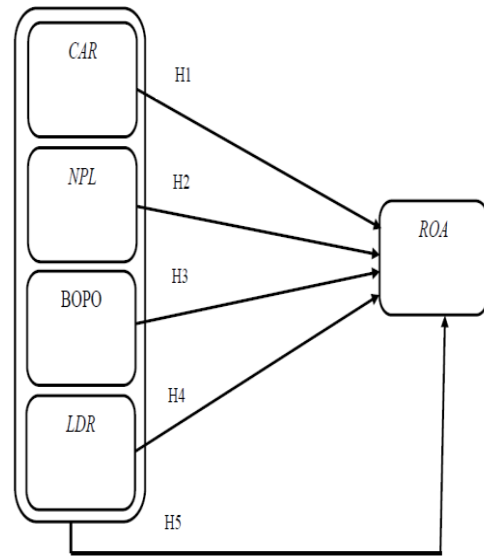

Picture 1. Research Model Framework

METHOD

Types of research.

This research is a quantitative type of research. Sugiyono (2016) explains that research with quantitative methods is research using numbers and the results are analyzed through various statistical methods. This study aims to determine the relationship between two or more variables. The variables used are Capital Adequacy Ratio (CAR), Non Performing Loans (NPL), Operational Income Operating Expenses (BOPO), and Loan to Deposit Ratio (LDR) as

independent variables. The Return on Assets (ROA) variable as the dependent variable.

Data Collection.

This study uses secondary data, in the form of bank financial ratios (CAR, NPL, BOPO, LDR, and ROA). Data collection is done by downloading the bank's annual financial statements by accessing the official website of PT Bursa Efek Indonesia through web.idx.id. Based on the results of data collection, 70 financial ratio data were obtained from 14 samples of private conventional commercial banks listed on the Indonesia Stock Exchange from 2013 to 2017.

Data Analysis.

The analyzed data will be processed using SPSS 22 Software. The first step will be to test the normality of the data to meet the classical assumptions of the regression model. Then multolinierity test, heterokedasticity test, and autocorrelation test were performed. These three tests aim to ensure that the data used are feasible and the regression model is tested. Then it will predict the amount of the coefficient of determination by looking

at the value of R2 Square in the statistical output. This is done to see the extent to which four independent variables affect the dependent variable. The last step is to analyze the relationship between the independent variable and the dependent variable. Simultaneous relationship will use the F test and partial relationships using the T test. All stages of the study were conducted to answer the hypothesis in this study.

RESULTS & DISCUSSION

Normality Test.

Measurement of data normality is needed to determine whether all data are normally distributed. This is because the requirement to do a regression test requires no problems in the normality of the data. Ghozali (2017) explains the guidelines for decision making in the normality test is if the significance value or Asymp. Sig. (2-tailed) > 0.05, then the data is declared normally distributed. Vice versa if the significance value or Asymp. Sig. (2-tailed) < 0.05, then the data distribution is not normal. Below is a table of normality test results as follows:

Table 2. Normality Test

One-Sample Kolmogorov-Smirnov Test		
		Unstandardized Residual
N		70
Normal Parameters ^a , b	Mean	.0000000
	Std. Deviation	.27623748
Most Extreme Differences	Absolute	.073
	Positive	.073
	Negative	-.056
Test Statistic		.073
Asymp. Sig. (2-tailed)		.200 ^{c,d}

Based on the results of the table above shows that the Asymp value. Sig. (2-tailed) of $0.2 > 0.05$. Therefore, it can be concluded that there is no normality problem in the data.

Multicollinearity Test.

Multicollinearity analysis aims to ensure that there are no multicollinearity problems in the regression model. This is because the requirements of a good regression model, where there is no multicollinearity problem. Guidelines for decision making regarding the presence or absence of multicollinearity in the regression model is, if the tolerance value > 0.10 and the value of variance inflation factor (VIF) < 10 , then there is no multicollinearity in the regression model. Vice versa, if the tolerance value < 0.10 and the value of the variance inflation factor (VIF) > 10 , then there is

multicollinearity in the regression model (Ghozali, 2017). Below is the table of Multicollinearity Test results as follows:

Table 3. Multicollinearity Test

Model	Collinearity Statistics	
	Tolerance	VIF
(Constant)		
CAR	.705	1.419
NPL	.637	1.569
BOPO	.529	1.891
LDR	.902	1.109

Based on the table above shows that the tolerance values of all independent variables, namely CAR, NPL, BOPO, and LDR > 0.10 and VIF value < 10 , then it proves that there is no multicollinearity problem in the regression model.

Autocorrelation Test.

Autocorrelation analysis is performed aimed to detect whether there is an autocorrelation problem in the regression model. The test was declared successful if no autocorrelation problems were found in the regression model. In this study the analysis of the autocorrelation problem was carried out through the Durbin-Watson test (DW test). Santoso (2015) explains in analyzing the results of the Durbin-Watson test (DW test) is as shown in table 3 below:

Table 4. DW Test Indicator

Value	Indicator
DW < -2	Autocorrelation +
-2 < DW < 2	No Autocorrelation
DW > 2	Autocorrelation (-)

Sources: Santoso (2015)

Below is the autocorrelation test results using the Durbin-Watson Test as follows:

Table 5. DW Test Results

Model Summary ^b				
R	R Square	Adjusted R Square	Std. Error of the Estimate	Durbin-Watson
.990 ^a	.979	.978	.28461	1.249

The test results in table 4 show that $-2 < 1,249 < 2$. Therefore it can be concluded that there is no autocorrelation problem in the regression model.

Heteroscedasticity Test.

This test is conducted to detect the problem of heteroscedasticity in the regression model. If there is a heteroscedasticity problem in the regression model, the classic assumption test cannot be declared successful. Therefore a good regression model is where there is no heteroscedasticity

problem in it. Guidelines for decision making in the heteroscedasticity test are if the significance value (sig) > 0.05 then there is no heteroscedasticity in the regression model. Vice versa if the significance value (sig) < 0.05, then heteroscedasticity occurs in the regression model (Ghozali, 2017). Below are the results of the heteroscedasticity test as follows:

Table 6. Heteroskedasticity Test

Model	Jnstandardized Coefficients		Standardized Coefficients	Sig.
	B	Std. Error	Beta	
(Constant)	.017	.242		.943
CAR	-.003	.005	-.076	.601
NPL	-.010	.020	-.076	.618
BOPO	.000	.001	.019	.911
LDR	.003	.002	.157	.225

The test results in table 5 show that all the independent variables (independent), have a significance value > 0.05 meaning that there is no heteroscedasticity problem in the regression model.

Coefficient of Determination (R2).

This test aims to determine the coefficient of determination (R2) is a regression test used to find out how far the level of ability of the model in explaining the variation of the dependent variable. The coefficient of determination (R2) lies between zero (0) and one (1)

(Ghozali, 2017). The higher the coefficient of determination (R²), it indicates that the ability of independent variables in explaining the dependent variable is getting better or the independent variables provide almost all the information needed to predict the variation of the dependent variable. Below is a table that shows the amount of the coefficient of determination (R²) as follows:

Table 7. Coefficient Determination

Model Summary			
R	R Square	Adjusted R Square	Std. Error of the Estimate
.990 ^a	.979	.978	.28461

Adjusted R Square value shows that the ability level of CAR, NPL, BOPO, and LDR variables in explaining its effect on the ROA variable is 97.8% while the rest is explained by other variables outside the tested variables. This shows the ability of the independent variable is able to explain the dependent variable comprehensively.

F-Test.

This test aims to determine how the influence of the overall independent variables (independent), together with the dependent variable (dependent). The guideline in analyzing the results of the F test is if the calculated F value > F table

then the independent variables simultaneously influence the dependent variable. And vice versa if the calculated F value < F table then the independent variables do not affect simultaneously the dependent variable (Ghozali, 2017). The F test results are as follows:

Table 8.F-Test

ANOVA ^a					
Model	Sum of Squares	Df	Mean Square	F	Sig.
Regression	250.277	4	62.569	772.431	.000 ^b
Residual	5.265	65	.081		
Total	255.542	69			

The test results show that the Sig value of 0.000 < 0.05 and F arithmetic 772,431 > 2.53 (F table) shows that simultaneously the CAR, NPL, BOPO, and LDR variables simultaneously influence ROA. This explains that the ability of independent variables together can influence the profitability of conventional commercial banks which are proxied by ROA.

T-Test.

This test aims to determine whether separately the independent variable (independent) has a significant effect on the dependent variable (dependent). Guidelines for decision making in this test is if the significance

value <0.05 then there is a significant influence on the dependent variable (dependent). Vice versa, if the significance value > 0.05 then there is no significant effect on the dependent variable (Ghozali, 2017). The following T test results are as follows:

Table 9. T-Test

Model	Unstandardized Coefficients		Standardized Coefficients	t	Sig.
	B	Std. Error	Beta		
(Constant)	9.794	.381		25.737	.000
CAR	.003	.008	.008	.356	.723
NPL	-.054	.031	-.039	1.744	.086
BOPO	-.087	.002	-.974	39.792	.000
LDR	-.009	.004	-.044	-2.320	.023

Based on the test results it can be seen that the significance value of the CAR variable of 0.723 > 0.05 indicates that the CAR variable does not have a significant effect on ROA so that Hypothesis 1 is rejected. The significance value of the NPL variable of 0.086 indicates that the NPL variable does not have a significant effect on ROA so that Hypothesis 2 is rejected. The significance value of the BOPO variable of 0.00 <0.05 indicates that the BOPO variable has a significant effect on ROA so that Hypothesis 3 is accepted as true. The significance value of the LDR variable of

0.23 <0.05 indicates that the LDR variable has a significant effect on ROA so that Hypothesis 4 is accepted as true.

Multiple Regression Model.

This analysis aims to determine the direction of the relationship between the independent variable and the dependent variable whether each independent variable is positively or negatively related and to predict the value of the independent variable increasing or decreasing (Ghozali, 2017). Below is a table showing the magnitude of the variable as follows:

Table 10. Regression Model Results

Model	Unstandardized Coefficients		Standardized Coefficients
	B	Std. Error	Beta
(Constant)	9.794	.381	
CAR	.003	.008	.008
NPL	-.054	.031	-.039
BOPO	-.087	.002	-.974
LDR	-.009	.004	-.044

Based on the results in the table above that the test can be seen a constant value of 9.794 shows that if the independent variable is considered constant (0), then the ROA variable will be constant at 9.794. The CAR variable regression coefficient of 0.008 indicates that, for every 1 unit increase in the CAR variable, the ROA will increase by 0.008.

NPL variable regression coefficient of -0.039 indicates that each decrease in 1 unit of ROA variable is 0.039. BOPO variable regression coefficient of -0.974 indicates that each reduction of 1 unit of BOPO variables will reduce the variable ROA of 0.974. LDR variable regression coefficient of -0.044 indicates that each decrease of 1 unit of the LDR variable will reduce the ROA variable by 0.044. Therefore, it can be concluded that the CAR variable has a positive relationship with ROA, the NPL variable has a negative relationship with ROA, the BOPO variable has a negative relationship with ROA, and the LDR variable has a negative relationship. Based on the results of the analysis, the multiple linear regression equation model can be formulated mathematically, where $ROA = 9,794 + 0.008 CAR - 0.039 NPL - 0.974 BOPO - 0.044 LDR$.

DISCUSSION.

The results showed that the Capital Adequacy Ratio (CAR) has a significance value of $0.732 > 0.05$ indicating that the variable Capital Adequacy Ratio (CAR) has no positive or negative effect on Return on Assets (ROA). The results of this study are in accordance with Soares & Yunanto

(2018), Azmy (2018), Anton & Nasri (2015) and Billian & Purwanto 2017 where the Capital Adequacy Ratio (CAR) has no significant effect on Return on Assets (ROA). This is due to $p\text{-values} > 0.05$ so that the hypothesis (H1) is rejected. However, the Capital Adequacy Ratio (CAR) has a positive relationship of 0.8%. Based on data that the increase and decrease in profitability proxied by Return on Assets (ROA) is not directly affected by the Capital Adequacy Ratio (CAR). It can be concluded that the capital adequacy ratio that is proxied by the Capital Adequacy Ratio (CAR) only gives an illustration that commercial banks have the sufficiency in terms of health required by Bank Indonesia of 5%. Commercial banks must be able to maintain sufficient capital to maintain customer confidence in the long run. Although statistically it has no effect on Return on Assets (ROA), but has a relationship to an increase in Return on Assets (ROA) of 0.8%. This indicates that the Capital Adequacy Ratio (CAR) as a condition of the bank's minimum capital obligation has been fulfilled. Besides that, this also indicates that banks have not utilized the existing capital to the maximum to produce profitability. The significance value of Non Performing

Loans (NPL) is $0.086 > 0.05$, indicating that Non Performing Loans (NPL) do not have a positive or negative effect on Return on Assets (ROA). Research conducted by Pinasti & Mustikawati (2018), Nursiana (2017), Soares & Yunanto (2018), and Aprilia & Handayani (2018) which explains that Non-Performing Loans (NPLs) have no significant effect on Return on Assets (ROA). This is due to $p\text{-values} > 0.05$ and hypothesis (H2) is rejected. However, the magnitude of the influence of Non-Performing Loans (NPL) was able to reduce Return on Assets (ROA) by -3.6%. Although statistically, it has no effect on Return on Assets (ROA), banks must be able to maintain soundness in lending. The magnitude of influence of -3.6% indicates that banks are still able to maintain the level of lending balanced with returns by customers.

The Operating Cost and Operational Income Ratio (BOPO) has a significance value of $0.00 < 0.05$ and a regression coefficient of -0.974 indicates that the BOPO ratio has a significant negative effect on Return on Assets (ROA). The value of $p\text{-values} < 0.05$ and the hypothesis (H3) are accepted stating that the ratio of Operating Costs and Operating Income (BOPO) significantly

influences Return on Assets (ROA). Research conducted by Hallunovi & Kume (2016), Azmy (2018), and Hutagalung et al (2013) concluded that the ratio of Operating Costs and Operating Income (BOPO) had a significant effect on Return on Assets (ROA). The magnitude of influence of 97.4% which indicates that banks must be able to balance the efficiency between costs and revenues so as to increase profitability. This is able to explain how banks have not been able to use operational costs efficiently. In addition, this also shows that the costs incurred for bank operations are higher than the income received from bank operations.

Loan to Deposit Ratio (LDR) has a significance value of $0.023 < 0.05$ and a regression coefficient of -0.044 indicates that the Loan to Deposit Ratio (LDR) variable has a significant negative effect on Return on Assets (ROA). The $p\text{-value} < 0.05$ and hypothesis (H4) states that the Loan to Deposit Ratio (LDR) significantly influences Return on Assets (ROA). The results of this study are in line with Soares & Yunanto (2018) and Effendi et al (2017) concluded that the Loan to Deposit Ratio affects the Return on Assets (ROA). The magnitude of the

influence of the Loan to Deposit Ratio (LDR) was able to reduce the level of profitability by -4.4%. This result illustrates that banks must be more vigorous in lending to customers. The strategy that can be done is to facilitate access to credit to the business world, digitizing services to customers, and increasing the promotion of getting credit by easy & fast ways to customers. This indicates that bank loans originating from third party funds are not channeled properly, so that the loans provided do not generate profits. In addition, this also indicates that the benefits derived from lending are only able to cover liabilities for withdrawals made by third parties.

Uhi F shows that the value of Sig 0.000 <0.05 and F count 772.431 > 2.53 (F table). Therefore it can be concluded that the CAR, NPL, BOPO, and LDR variables affect simultaneously or jointly on the ROA variable. This result is supported by previous research conducted by (Alifah, 2014) which states that, CAR, NPL, BOPO, and LDR simultaneously influence ROA.

CONCLUSION

The results of data processing and analysis that have been done show that the Capital Adequacy Ratio (CAR) individually has no effect on Return on Assets (ROA). Non-Performing Loans

(NPLs) individually have no effect on Return on Assets (ROA). Operating Costs and Operating Income (BOPO) individually have a significant negative effect on Return on Assets (ROA). Loan to Deposit Ratio (LDR) individually has a significant negative effect on Return on Assets (ROA). CAR, NPL, BOPO, and LDR simultaneously influence ROA variables. Therefore, it can be seen that the low level of operational cost efficiency and the low level of effective lending, are factors that cause a decrease in bank Return on Assets (ROA).

The results of this study provide an overview of the components that must be considered in an effort to increase profitability. The aspects of capital adequacy and the smooth return of credit will have an indirect impact on bank profitability. Capital adequacy will provide convenience and increase customer confidence in saving funds. Banks must continue to provide strict supervision in the smooth level of credit repayments. This will have an indirect impact on bank health and reduce profitability.

The aspect of operational balance must be maintained in order to run the business efficiently. Cost and revenue flows must be closely monitored and

able to provide increased revenue to the company. The aspects of credit distribution must be expanded and able to be accessed by all levels of society. Both of these aspects are able to have a direct impact on profitability proxied by Return on Assets (ROA).

Based on the analysis of the bank's Capital Adequacy Ratio (CAR) which is in good condition, it should be maintained and even increased again, so that it can increase the bank's Return on Assets (ROA). Then the Non-Performing Loans (NPLs) of banks which are in a pretty good position, should be maintained and even lowered again, so that they can help increase bank's Return On Assets (ROA). The ratio of bank operational costs and operating income (BOPO), which is a factor in the decline in return on assets (ROA), must be reduced in order to increase bank return on assets (ROA). Loan to Deposit Ratio (LDR) of banks which is also a cause of decreasing bank Return on Assets (ROA), must be reduced in order to help increase bank Return on Assets (ROA). The results of this study have found two things that are causing the decline in bank Return on Assets (ROA), namely the ratio of BOPO and LDR. It is therefore recommended for further research to

add more samples and research variables in order to obtain accurate research results and broader research benefits.

REFERENCES

- Alifah, Y. B. (2014). "Pengaruh CAR, NPL, BOPO, dan LDR terhadap Profitabilitas Bank (ROA) Pada Perusahaan Perbankan Yang Terdaftar Di Bursa Efek Indonesia Periode 2009-2012". *Skripsi*. Program Sarjana (S1) Ekonomi. Universitas Negeri Yogyakarta. Yogyakarta.
- Anggreni, M. R., & Suardhika, M. S. (2014). Pengaruh Dana Pihak Ketiga, Kecukupan Modal, Risiko Kredit Dan Suku Bunga Kredit Terhadap Profitabilitas Bank BUMN Tahun 2010-2012. *E-Jurnal Akuntansi*, 27-37.
- Antoni, A., & Nasri, M. (2015). "Profitability Determinants of Go-Public Bank in Indonesia: Empirical Evidence after Global Financial Crisis". *International Journal of Business and Management Invention*. Volume 4 Issue 1. pp 37-46.
- Aprilia, J., & Handayani, S. R. (2018). Pengaruh Capital Adequacy Ratio, Biaya Operasional Per Pendapatan Operasional, Non-Performing Loan,

- dan Loan to Deposit Ratio Terhadap Return on Asset dan Return on Equity. *Jurnal Administrasi Bisnis*, 61(3), 172–182. Retrieved from <http://administrasibisnis.studentjournal.ub.ac.id/index.php/jab/article/viewFile/2611/3005>
- Azmy, A. (2018). Analisis Pengaruh Rasio Kinerja Keuangan Terhadap Profitabilitas Bank Pembiayaan Rakyat Syariah di Indonesia. *Jurnal Akuntansi*, 22(1). <https://doi.org/10.24912/ja.v22i1.326>
- Bhattarai, Y. R. (2016). "Effect of Non-Performing Loan on the Profitability of Commercial Banks in Nepal". *The International Journal Of Business & Management*. Volume 4 Issue 6. pp 435-442.
- Bilian, F., & Purwanto, P. (2017). Analisis Pengaruh CAR, NIM, BOPO, dan LDR terhadap Profitabilitas Bank Persero. *Firm Journal of Management Studies*, 2(1).
- Dendawijaya, L. (2000). *Manajemen Perbankan*. Jakarta: Ghalia Indonesia
- Effendi, M. S., Hady, H., Rismayadi, B., & Maemunah, M. (2017). "The Determinants of Banking Credit Disbursement and its Implications on the Return on Assets (ROA): Empirical Study to the Banks Listed on Indonesian Stock Exchange". *International Journal of Economic Research*. Volume 18 Issue 2. pp 129-154.
- Ghozali, I. (2017). *Aplikasi Analisis Multivariate SPSS 23*. Semarang: Badan Penerbit Universitas Diponegoro.
- Hakim, L., & Sugianto. (2018). "Determinant Profitability and Implications on the Value of the Company: Empirical Study on Banking Industry in IDX". *International Journal of Economics and Financial Issues*. Volume 8 Issue 1. pp 205-216.
- Hallunovi, A., & Kume, K. (2016). Determinants Of Profitability (ROA) In Albanian Banking System. *International Scientific Conference*, 391-399.
- Haneef, Shabaz, dkk. 2012. Impact of Risk Management on Non-Performing Loans and Profitability of Banking Sector of Pakistan. *Journal of Business and Social Science*, 3, (7)
- Hantono. (2017). "Effect Of Capital Adequacy Ratio (CAR), Loan to

- Deposit Ratio (LDR), And Non Performing Loan (NPL) to Return On Asset (ROA) Listed In Banking In Indonesia Stock Exchange". *International Journal of Education and Research*, Volume 5 Nomor 1. pp 69-80.
- Haritsman, Egi. Bahtiar, Usman. (2017). Faktor-Faktor Yang Mempengaruhi Profitabilitas Bank Konvensional Yang Terdaftar di Bursa Efek Indonesia. *Kompetensi-Jurnal Manajemen Bisnis*, Vol 12, No.1 Januari-Juni 2017. UKRIDA.
- Harun, U. (2016). Pengaruh Ratio-ratio Keuangan Car, Ldr, Nim, Bopo, Npl Terhadap Roa. *Jurnal Riset Bisnis dan Manajemen*, 4(1), 67-82.
- Hindarto, C. (2011). *ANALISIS Pengaruh CAR, NIM, LDR, NPL, BOPO DAN KAP Terhadap Return on Assets (Studi Perbandingan pada Bank dengan Total Aset diatas 1 Trilyun dan dibawah 1 Trilyun Periode Tahun 2005-2008)* (Doctoral dissertation, Diponegoro University).
- Hutagalung, E. H., Djumahir, & Ratnawati, K. (2013). "Analisa Rasio Keuangan terhadap Kinerja Bank Umum di Indonesia". *Jurnal Aplikasi Manajemen*. Volume 11 Nomor 1. pp 122-130
- Kashmir. (2002). *Manajemen Perbankan*. Jakarta: PT. Raja Grafindo Persada.
- Mawaddah, N. (2015). Faktor-Faktor Yang Mempengaruhi Profitabilitas Bank Syariah. *ETIKONOMI*, 14(2). <https://doi.org/10.15408/etk.v14i2.2273>
- Manurung, A. H. (2015). "Effects of Bonds Issuance on Banking Performance". *Journal of Applied Finance & Banking*. Volume. 5 Nomor 5. pp 113-124.
- Matindas, A. M., Pangemanan, S. S., & Saerang, D. P. (2010). "Pengaruh Capital Adequacy Ratio (CAR), BOPO, dan Non Performing Loan (NPL) Terhadap Kinerja Keuangan Perbankan di Indonesia". *Jurnal Fakultas Ekonomi dan Bisnis Magister Akuntansi Universitas Sam Ratulangi Manado*. pp 52-66.
- Muttaqin, H. F. (2017). Pengaruh CAR, BOPO, NPL dan LDR terhadap ROA pada Bank Konvensional di Indonesia. *E-Jurnal Administrasi Bisnis Unmul*, 5(4).
- Ningsukma, H., & Rafsanjani, H. (2016). Pengaruh Internal Capital Adequacy Ratio (CAR), Financing to Deposit Ratio (FDR), dan Biaya Operasional Per Pendapatan Operasional (BOPO) dalam

- Peningkatan Profitabilitas Industri Bank Syariah di Indonesia.
- Nursiana, A. (2017). "Effect of Non-Performing Loans to Profitability of Banks in Indonesia". *International Journal of Applied Business and Economic Research*. Volume 15 Nomor 10. pp 203-208.
- Pinasti, W. F., & Mustikawati, R. I. (2018). Pengaruh CAR, BOPO, NPL, NIM DAN LDR Terhadap Profitabilitas Bank Umum Periode 2011-2015. *Nominal, Barometer Riset Akuntansi Dan Manajemen*, 7(1). <https://doi.org/10.21831/nominal.v7i1.19365>
- Putrianingsih, D. I., & Yulianto, A. (2016). Pengaruh Non-Performing Loan (NPL) dan Capital Adequacy Ratio (CAR) terhadap Profitabilitas (Studi Kasus pada Perusahaan Perbankan yang Terdaftar di BEI Periode 2010-2013). *Management Analysis Journal*, 5(2).
- Rizkika, R., Khairunnisa, K., & Dillak, V. J. (2017). Analisis Faktor-faktor Yang Mempengaruhi Profitabilitas Bank Umum Syariah Di Indonesia (studi Pada Bank Umum Syariah Yang Terdaftar Di Otoritas Jasa Keuangan Selama Tahun 2012-2015). *eProceedings of Management*, 4(3).
- Siamat, D. (2004). *Manajemen Lembaga Keuangan*. Edisi Keempat. Jakarta: Lembaga Penerbit Fakultas Ekonomi Universitas Indonesia
- Soares, P., & Yunanto, M. (2018). "The Effect of NPL, CAR, LDR, OER, and NIM to Banking Return On Asset". *International Journal of Economics, Commerce and Management United Kingdom*, Volume 6 Issue 3. pp 40-55.
- Stephani, R., Adenan, M., & Hanim, A. (2017). "Analisis Pengaruh Rasio Keuangan Terhadap Kinerja Bank Umum di Indonesia". *e-Journal Ekonomi Bisnis dan Akuntansi*. Volume 4 Nomor 2. pp 192-195.
- Sugiyono. (2016). *Metode Penelitian Kuantitatif, Kuantitatif, dan R&D*. Bandung: ALFABETA CV.
- Sudarmawanti, E., & Pramono, J. (2017). Pengaruh CAR, NPL, BOPO, NIM Dan LDR Terhadap ROA (Studi Kasus Pada Bank Perkreditan Rakyat Di Salatiga Yang Terdaftar Di Otoritas Jasa Keuangan Tahun 2011-2015). *Jurnal Ilmiah Among Makarti*, 10(19).
- Sutrisno, B. (2018). Determinan Profitabilitas Bank Umum

- Konvensional Terdaftar di Bursa Efek Indonesia. *Esensi: Jurnal Bisnis Dan Manajemen*, 8(1).
<https://doi.org/10.15408/ess.v8i1.6554>
- Vernanda, S. D., & Widyarti, E. T. (2016). "Analisis Pengaruh CAR, LDR, NPL, BOPO, dan SIZE Terhadap ROA (Studi pada Bank Umum Konvensional yang Terdaftar di Bursa Efek Indonesia Periode 2010-2015)". *Diponegoro Journal of Management*. Volume 5 Nomor 3. pp 1-13.
- Yogianta, C. W. E. (2013). Analisis Pengaruh CAR, NIM, LDR, NPL dan BOPO Terhadap Profitabilitas Studi Pada Bank Umum yang Go Publik di Bursa Efek Indonesia Periode Tahun 2002-2010 (Doctoral dissertation, Diponegoro University).